

The A-Class.



Mercedes-Benz



from Mercedes-Benz. The A-Class is the car for a new era and a new generation. A car that  
. Unadulterated agility and efficient with it? Of course. Comfort and technology in a brand  
options which are geared to your personality and not vice versa? Just let yourself be guided  
ing metres, you will feel it in the new A-Class - the pulse of a new generation. Either for  
con inside. It expels boredom from the street. And gives you an easy ride in the process  
characteristic Mercedes. And at the same time very, very different. Hello, A-Class! An exper  
sweeping lines - in a perfect rhythm for light shows. And sinewy with it, athletic like a  
your personality, your A-Class. Three possible design and equipment lines, three differ  
Even more "Me" with the three optional Design packages: an extravagant exterior in the  
re package. The A-Class: a Mercedes-Benz where its genes are concerned. But it clearly  
m the street. Sit **The pulse of a new generation.** at the wheel and steer the whole world.  
be there every bit of the way. And you won't be alone in any situation in the real world



It is an unbridled attack: on your eyes, on your heart, on that which you normally expect from Mercedes-Benz. The A-Class is the car for a new era and a new generation. A car that wants it all and makes no compromises. A design that is the spitting image of the future? Here it is. Unadulterated agility and efficient with it? Of course. Comfort and technology in a breathtaking symbiosis? Climb on in

and experience it for yourself. Equipment and appointments options which are geared to your personality and not vice versa? Just let yourself be guided by your style. And when you are then finally sitting in it and drive the first of many, many exciting metres, you will feel it in the new A-Class – the pulse of a new generation.

At a glance | from page 4    Insight | from page 26

#### Featured models:

**A 250 | polar silver metallic** | cover and from page 4

AMG Line design and equipment line | Twin-spoke AMG light-alloy wheels, black ARTICO man-made leather/DINAMICA microfibre upholstery, carbon fibre look trim

**A 200 | non-metallic jupiter red** | from page 12

Style design and equipment line | 5-twin-spoke light-alloy wheels, black/white ARTICO man-made leather/fabric upholstery, black matrix-look trim

**A 250 Sport – engineered by AMG | polar silver metallic** | page 2 and from page 18

AMG Line design and equipment line | 5-twin-spoke AMG light-alloy wheels, black leather upholstery, carbon fibre look trim

**A 45 AMG 4MATIC | cirrus white** | from page 22

Multi-spoke AMG light-alloy wheels, Night package, black ARTICO man-made leather/DINAMICA microfibre upholstery, carbon fibre look trim

The illustrations may include accessories and optional extras which do not form part of the standard specification.

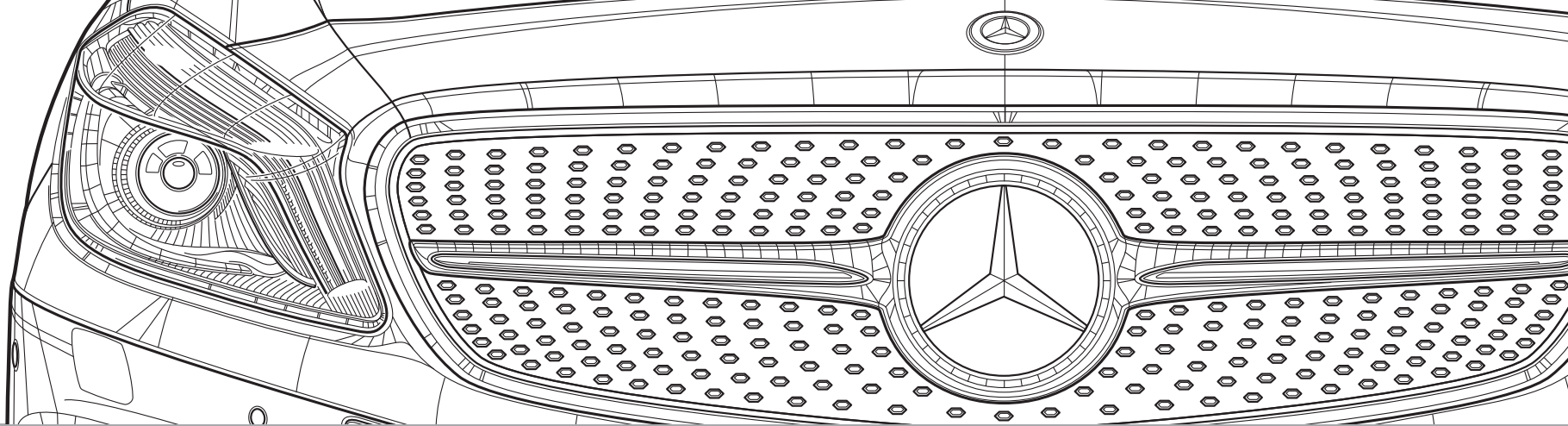

**For motoring pleasure:** Mercedes-Benz Intelligent Drive, BlueEFFICIENCY, diesel and petrol engines, transmissions and chassis.

Drive system & chassis | from page 32

**For safety:** assistance systems which can prevent accidents and minimise the consequences of accidents, such as ATTENTION ASSIST, COLLISION PREVENTION ASSIST, DISTRONIC PLUS proximity control and PRE-SAFE®.

Safety | from page 38

**For relaxed driving:** standard-specification and optional comfort, for example multimedia and assistance systems, climate control, and seats.

Comfort | from page 42

**For top athletes:** everything about the powerful sports model – engineered by AMG.

Model variants | from page 48

**For expressionists:** A 45 AMG 4MATIC exterior, interior, technology and Performance Studio.

AMG | from page 50

**For individualists:** generous standard equipment, optional design and equipment lines Style, Urban, AMG Line plus Night, Exclusive and AMG Exclusive package, wheels and genuine accessories.

Equipment and appointments | from page 58

**For all-round service:** MercedesCard, Mercedes-Benz Financial Services, Mercedes-Benz mobility, Mercedes-Benz Museum, test drive, Interactive Owner's Manual and Mercedes-Benz Guides, mobile internet, service contracts, accident repairs.

Services | from page 84

**For lovers of detail:** dimensions, paintwork and technical data.

Facts & colours | from page 86



# 1 look\*

\* And you won't believe your eyes:  
what a Mercedes!

Either for or against, complacency is not an option. Non-conformist from the outside and quite the style icon inside. It expels boredom from the street. And gives you an easy ride in the process. High-tech: it goes without saying. Safe: no question. Efficient: naturally. It could not be a more characteristic Mercedes. And at the same time very, very different. Hello, A-Class!



# 130 bpm\*

\*When the view leaves you speechless,  
the heart speaks volumes.

An expression of pulsating life: defined edges alongside tautly tensioned surfaces: concave curves, convex sweeping lines – in a perfect rhythm for light shows. And sinewy with it, athletic like a coupé. Lit-up eyes included: this is what a portrait of the A-Class sounds like.







# 1\*

\*Endless equipment options.  
And only one that sets the tone.

Your head, your style, your personality, your A-Class. Three possible design and equipment lines, three confident statements: dynamic elegance, urbane style or sporty through and through with the AMG Line. Even more “Me” with three optional Design packages: an extravagant exterior in the Night package, high-quality details in the Exclusive package, sporty presence in the AMG Exclusive package. The A-Class: a Mercedes-Benz where its genes are concerned. But it clearly takes after you.







# 800 x 480\*

\*The offline resolution:  
the COMAND Online.

Sit at the wheel and steer the whole world. A full 17.8 cm display: your window to the web of possibilities. Surf in the browser, search with Google®, share on Facebook® and be there every bit of the way. And you won't be alone in any situation in the real world, either: the electric parking brake, Active Parking Assist, reversing camera and HOLD function support your motoring pleasure. Technology that makes it easier to be human.

# > 1000 km\*

\*Every refuelling stop is something special.  
Good for progress and bank balance alike.

The A-Class is a true endurance athlete. The economical consumption from 3.6 litres over 100 kilometres takes you further than you think. Through efficient engines with direct injection and turbocharging. And the standard-specification ECO start/stop function which also helps to put the brakes on consumption at red traffic lights. The very essence of BlueEFFICIENCY.











# 5 + 11\*

\*More perception and less risk.

Whenever the 5 senses reach their limits they are on hand: 11 assistance systems. Part of the standard specification in the A-Class: the radar-based COLLISION PREVENTION ASSIST safety system, the ATTENTION ASSIST system and Hill-Start Assist. Even more safety on request: the DISTRONIC PLUS proximity control and the PRE-SAFE® system. Technologies which can ensure that dangers keep their distance from you.





# 6.6 s\*

\*Sprint immediately: from 0 to 100 km/h in your best time.

Off and away with a lasting impression. A well-exercised heart as a drive system: high-torque and efficient 4-cylinder petrol and diesel engines. From one gear to another without any interruptions with the optional dual clutch transmission 7G-DCT. Your finger on the pulse of the road: the Direct-Steer system and sports suspension in the optional Dynamic Handling package. An athlete where looks are concerned, too: with a diamond radiator grille and sports seats that have really earned their name. Don't drive off for less fun.







A silver car is shown from a low-angle, side-rear perspective, driving on a road. The background is a blurred city skyline under a bright sky, suggesting motion and speed.
$$C_d = 0.27^*$$

\*If you save on wind resistance, you also save on consumption.

The A-Class: a body with such optimum flow that the air becomes short of breath. The result: a  $c_d$  value like that of notchback saloons. The advantage of this drawback: less fuel consumption, fewer fuelling stops. Pssst: this is how we have also reduced the wind noise.





A white Mercedes-AMG A45 is shown from a rear three-quarter view, driving on a racetrack. The car is in motion, with a blurred background of a sunset sky and a stone wall. The car's rear wheel and side mirror are prominent.

# 450 Nm\*

\*Refresh your knowledge of physics  
in 4.6 seconds.

The A 45 AMG stands for sport, dynamism, power and above all for itself. Because with its AMG 2.0-litre 4-cylinder turbocharged engine it achieves 360 hp, making it the undisputed leader in its segment. This means more hp, more torque and more AMG, sending the vehicle shooting over the road and the adrenaline through your veins.

A silver Mercedes-AMG A45 is shown from a rear three-quarter view, driving on a racetrack. The track has a red and blue painted curb. In the background, there are concrete barriers and a fence. The sky is a mix of orange and blue, suggesting sunset or sunrise.

# 6.9 litres\*

\*No other vehicle drives past so many filling stations with this much power.

With great strength the A 45 AMG also assumes a lot of responsibility. By way of example, with 360 hp and 450 Nm it consumes an average of just 6.9 litres per 100 kilometres. Because for sports cars from Affalterbach every drop counts just as much as every tenth of a second.



# California think-tank.

There's something in the air in Palo Alto. It appears to vibrate when the Californian sun sends a new day packed full of brainwaves shining into the foothills of Silicon Valley.

Renowned universities and visionary start-ups spur each other on to attain maximum performance – like the segments of a hard disc they are in constant communication.

Mercedes-Benz Research & Development Center North America is also located at the heart of this seat of progress. The most diverse disciplines carry out research here into tomorrow's innovations: specialists such as

user interface designers plus software and hardware engineers are networking the digital lifestyle with the digital drive style. Cross-functional cooperation is the foundation for their working relationship.

And with their creative power they do not stop at the walls of the development centre in California. That is why these are coated with a special paint finish which allows them to be written on with pens. This accelerates the creative process, saves paper and makes it easier to think in all directions. An ability without which the car would never have been invented and which is indispensable for its future development.

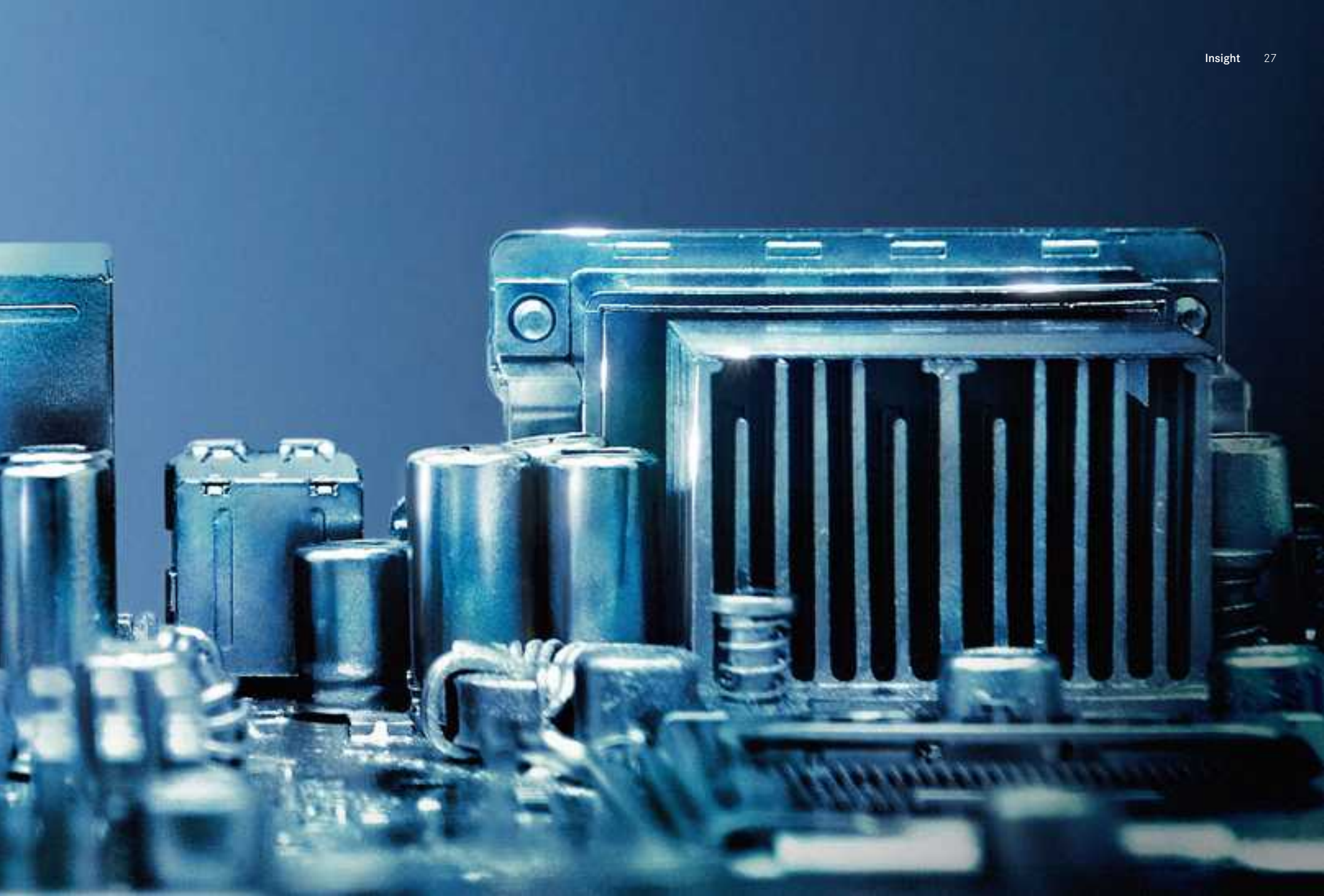



Facts & colours. Metallic paints. Climate control. Seats. ESP<sup>®</sup>. Dimensions. Standard equipment. Alloy wheels. Top speed. Chassis & suspension. Facts & colours. Optional extras. Fuel consumption. Facts & colours. Climate control. Seats. ESP<sup>®</sup>. Dimensions. Standard equipment. Alloy wheels. Memory function. Transmission. Surround sound system. Wheels. Test drive. Interior and trim. Assistance systems. Safety. Metallic paints. Petrol engines. Sound system. Optional extras. Fuel consumption. Interior. Airbags. LED daytime running lamps. Paintwork. Standard equipment. Light. Multimedia systems. Drive system. Test drive. Equipment and interior. Interior. Acceleration. CO<sub>2</sub> emissions. Test drive. Environment. Leather. Comfort. Cylinders. m. Metallic paints. Petrol engines. Facts & colours. Acceleration. Sound system. AMG. Consumption. Drive system. Interior. Airbags. LED daytime running lamps. Engines. AMG. Interior. Test drive. **The facts.** Paintwork. Total displacement. Climate control. Seats. Wheel. Alloy wheels. Memory function. Transmission. Surround sound system. Dimensions. Interior.

**32 Mercedes-Benz Intelligent Drive****33 BlueEFFICIENCY****34 Diesel engines**

4-cylinder

**35 Petrol engines**

4-cylinder

**36 Transmissions**

6-speed manual transmission

7-speed dual clutch transmission

7G-DCT

**37 Chassis & suspension**

Chassis and steering

Sports suspension

Direct-Steer system

4MATIC

**38 Integral safety concept**

ATTENTION ASSIST

COLLISION PREVENTION ASSIST

ADAPTIVE BRAKE

DISTRONIC PLUS proximity control

Lane Keeping Assist/Blind Spot Assist

Intelligent Light System

PRE-SAFE® system

Active bonnet

Restraint systems

Mercedes-Benz emergency call system

Measures after an accident

**42 Multimedia systems**

COMAND Online

Drive kit for the iPhone®

Audio 20 CD

Becker® MAP PILOT

Harman Kardon® Logic 7®

surround sound system

**44 Assistance systems**

Reversing camera

Active Parking Assist, including

PARKTRONIC

Speed Limit Assist

**45 Light and climate control**

Light and Sight package

THERMOTRONIC

**46 Seats**

Seat Comfort package

4-way lumbar support

Electric seat adjustment with

memory function

**47 Roof and space**

Panoramic sliding sunroof

Luggage compartment

Stowage Space package

**48 Sports model A 250****Sport – engineered by AMG**



- |  |   |  |   |
|--|---|--|---|
| <p>50 <b>A 45 AMG 4MATIC exterior</b></p> <p>52 <b>A 45 AMG 4MATIC interior</b></p> <p>54 <b>A 45 AMG 4MATIC technical details</b><br/>         AMG 2.0-litre 4-cylinder turbocharged engine<br/>         AMG high-performance brake system<br/>         AMG SPEEDSHIFT DCT 7-speed sports transmission<br/>         The all-wheel drive system<br/>         AMG Performance 4MATIC<br/>         AMG speed-sensitive sports steering and AMG sports suspension</p> <p>56 <b>AMG Performance Studio</b></p> | <p>58 <b>Equipment packages, including upholstery and trim</b><br/>         Standard equipment<br/>         Style design and equipment line<br/>         Urban design and equipment line<br/>         AMG Line design and equipment line<br/>         Night package<br/>         Exclusive package<br/>         AMG Exclusive package</p> <p>78 <b>Standard equipment</b></p> <p>79 <b>Optional extras</b></p> <p>80 <b>Wheels</b><br/>         Standard wheels<br/>         Optional wheels<br/>         AMG wheels</p> <p>82 <b>Genuine accessories</b></p> | <p>84 <b>Services</b><br/>         MercedesCard<br/>         Mercedes-Benz Financial Services<br/>         Mercedes-Benz mobility<br/>         Mercedes-Benz Museum<br/>         Test drive<br/>         Interactive Owner's Manual and Mercedes-Benz Guides<br/>         Mobile internet<br/>         Service contracts<br/>         Accident repairs</p> | <p>86 <b>Dimensions</b></p> <p>86   89 <b>Paintwork</b></p> <p>87 <b>Technical data</b></p> |
|--|---|--|---|

## Mercedes-Benz Intelligent Drive – a new era in mobility.

Our engineers focus on the future every day, the aim being to implement innovative technology. This aspiration has resulted in developments that have had a lasting impact on automotive engineering. In other words, we are working to make sure that a Mercedes-Benz will always be ahead of its time.

We have developed one groundbreaking solution after another to get closer to realising our vision of safe and accident-free driving. Innovative technologies such as the anticipatory occupant protection system PRE-SAFE® and DISTRONIC PLUS proximity control first made it onto the road in a Mercedes-Benz, setting new standards in vehicle safety. This is because it was the first time that active and passive systems had been combined – for even better protection and driving comfort.

Mercedes-Benz Intelligent Drive takes things a stage further by intelligently combining the sensors from various safety and assistance systems. For us, it's a logical progression as the traffic situation has changed. There are more vehicles on the road, the driver's job is becoming more complex and the likelihood of distraction is increasing.

To give the driver even more assistance and deal with the specific situation effectively, we have revolutionised the car once more: a Mercedes-Benz is now able to “see” better in all dimensions. It has an even better view of the road and other road users, and it can react to what it sees.

We have developed a stereo camera system that is capable of seeing in three dimensions. Together with further sensors, this produces a 360° all-round view – a precise image of the surroundings. If the driving assistance and safety systems detect danger, they can respond within a fraction of a second to provide the driver with the right support for the situation in hand: by braking in dangerous situations, for example, or by masking out the portion of the main beam affecting oncoming traffic.

Pioneer of innovation – Mercedes-Benz Intelligent Drive once again underlines our ambition to lead and points the way ahead to accident-free and autonomous driving. The following pages include further information about our safety and comfort systems. They are available as standard equipment or optional extras for the A-Class, depending on the model specification; further details can be found on pages 38–41 and 44.

## BlueEFFICIENCY – fast forward to tomorrow.

Mercedes-Benz brings the future of motoring to the road faster. With ever more efficient vehicles and a production process that wastes fewer and fewer resources. We call this all-encompassing approach BlueEFFICIENCY. By way of example, BlueTEC technology for the diesel engine reduces the nitrogen oxides in the exhaust gases by up to 90%, while the natural-gas drive NGT drastically reduces

emissions and fuel costs. Our hybrid models, featuring an intelligent combination of internal combustion engine and electric drive, can reduce fuel consumption significantly. What's more, electromobility is also moving into the fast lane with the SLS AMG Coupé Electric Drive. Meanwhile, technical and aerodynamic enhancements right down to the last detail make the BlueEFFICIENCY Editions

available in selected model series true champions of efficiency.

But every A-Class model already boasts a raft of BlueEFFICIENCY features – comprehensive vehicle optimisation measures that have been adapted specifically for this model series.



- 1 Ancillary components controlled to save energy.
- 2 Adjustable radiator shutter (A 180) and controlled oil pump.
- 3 Particularly efficient alternator.
- 4 Engines with direct petrol injection; optimised diesel engines.
- 5 Excellent aerodynamics with a  $c_d$  value of 0.27.
- 6 Standard-specification ECO start/stop function.
- 7 Standard-specification ECO display.
- 8 7G-DCT dual clutch transmission (as an option).
- 9 Reduced rolling resistance on tyres and wheels.
- 10 Intelligent weight reduction through aluminium (front wings, bonnet and other components).

## Diesel engines.

More economical, cleaner, more powerful: the A-Class also signals the launch of the current Mercedes-Benz diesel technology. The engines are powerful and quiet. And they impress with their optimised emission and fuel-consumption figures.

**4-cylinder in-line engines.** The 4-cylinder diesel engines display hallmark Mercedes qualities: they boast a hefty torque and an immediate response, even in the lower engine speed range. At the same time the diesel engines are modest when it comes to fuel consumption, they are low on emissions, impress with their significantly improved quiet-running characteristics and with their reduced vibrations.

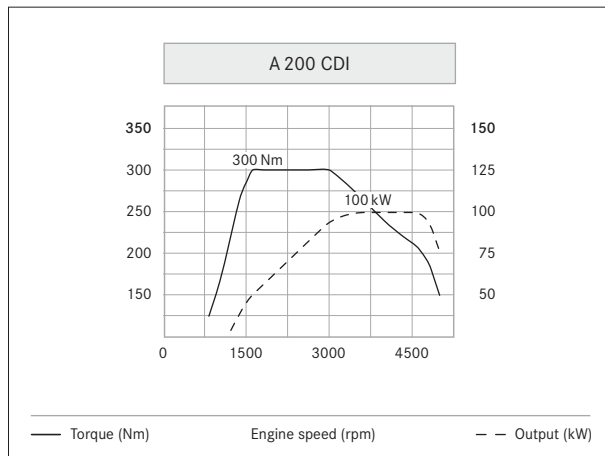

The A 200 CDI achieves its peak torque of 300 Nm at between just 1600 and 3000 rpm.

The fourth-generation common-rail diesel technology has an injection pressure that has been increased to 1800 bar, optimised combustion chambers and precise solenoid valve injectors. Improved ignition pressure and a turbocharger with a variable nozzle turbine ensure a high torque in every engine speed range. Intelligently controlled ancillaries contribute towards increasing the efficiency. All the diesel



The 4-cylinder diesel engine in the A 200 CDI combines pulling power with humble consumption and low emissions.

engines have an ECO start/stop function which ensures that the engine is temporarily switched off when the vehicle is at a standstill.

The diesel engines are now available in the following output levels: in the A 180 CDI with 80 kW (109 hp) and a maximum torque of 260 Nm (also as the A 180 CDI BlueEFFICIENCY Edition) and in the A 200 CDI with 100 kW (136 hp) and a maximum torque of 300 Nm. The A 220 CDI with 125 kW (170 hp) and a maximum torque of 350 Nm already complies with the Euro 6 emission class.

## Petrol engines.

The petrol engines were developed with the aim of reducing fuel consumption and emissions without compromising on output and ride comfort.

**4-cylinder in-line engines.** The 4-cylinder powerplants with a displacement of 1.6/2.0 litres, direct petrol injection, variable valve timing and a turbocharger offer excellent figures when it comes to both torque and power, plus exemplary quiet-running characteristics, not to mention appropriately low fuel consumption and emissions.

The high-pressure direct injection via precise piezo injectors and an enhanced combustion process facilitate virtually total combustion and thus higher efficiency, which means that the fuel can be used more efficiently. The variable valve control results in an optimum cylinder charge level and therefore consumption benefits, which also come courtesy of the lower weight, less internal friction plus ancillaries controlled as required. And last but not least the standard-specification ECO start/stop function raises the efficiency of the engines.

The 4-cylinder petrol engines are now available with the following power outputs: in the A 180 with 90 kW (122 hp) and a maximum torque of 200 Nm (also as the A 180 BlueEFFICIENCY Edition), in the A 200 with 115 kW (156 hp) and a maximum torque of 250 Nm and in the A 250 with 155 kW (211 hp) and a maximum torque of 350 Nm (also as the A 250 Sport and A 250 4MATIC). The new A 45 AMG



The 4-cylinder A 180 BlueEFFICIENCY petrol engine boasts direct injection via piezo injectors and a turbocharger.

4MATIC achieves 265 kW (360 hp) with a maximum torque of 450 Nm. All the petrol engines have low emissions and thus already comply with the requirements of the Euro 6 emission class.

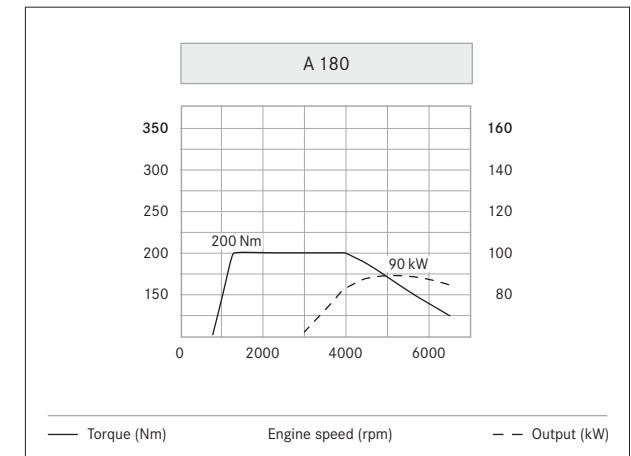

The A 180 delivers a peak torque of 200 Nm between 1250 and 4000 rpm.

## Transmission.

Whether you choose the manual transmission or the optional dual clutch transmission 7G-DCT, whether you prefer an economical or sporty driving style – both transmissions for the A-Class are optimally matched to the engine. They set benchmarks where shift comfort, efficiency and weight optimisation are concerned.

**6-speed manual transmission** (standard for A 180 CDI, A 200 CDI, A 180 and A 200). The 6-speed manual transmission facilitates rapid gear changes through its short shift travel. The standard-specification ECO start/stop function sees to it that the engine is temporarily switched off when the vehicle is standing at traffic lights and in jams, thus that fuel is saved. The standard-fit ECO display in the instrument cluster also supports an efficient driving style. As the BlueEFFICIENCY Edition the A 180 CDI and A 180 are equipped with an efficiency-optimised 6-speed manual transmission.

**7-speed dual clutch transmission 7G-DCT** (standard for A 180 CDI [7G-DCT], A 220 CDI, A 250, A 250 Sport and the new all-wheel drive variant A 250 4MATIC). With seven forward gears and one reverse gear the dual clutch transmission combines comfort, sportiness and economy. It comprises two sub-transmissions which each have their own clutch. One of these sub-transmissions supports the “even” gears and the other sub-transmission the “odd” ones.

During acceleration or braking the next highest or next lowest gear is the default setting on the sub-transmission not in use at the time. When changing gear there is then a switchover to the other sub-transmission. This means that the gear change takes place without any delay or loss of traction. Both the clutch actuation and the gear change occur fully automatically, which is facilitated by particularly



The 7G-DCT enables gear shifting with no interruptions in tractive power.

smooth gear shifting without any interruption to traction. The preselectable shift programs “Economy”, “Sport” and “Manual” can be set via a switch on the centre console. The programs differ from one another with regard to the shift characteristics and shift speed. In “Sport” mode, changing up a gear takes place at higher engine speeds than is the case in “Economy” mode, changing down a gear earlier. The “Manual” mode, for example, gives sporty drivers the option of performing gear shifting manually via the steering-wheel gearshift paddles included in the package. Also integrated is the ECO start/stop function for reducing fuel consumption and the new gearshift recommendation display in “Manual” mode for efficient driving. In addition to this the gear that is currently engaged is always shown in the instrument cluster. An ergonomic DIRECT SELECT lever and the cruise control<sup>1</sup> and SPEEDTRONIC<sup>1</sup> functions are already part of the equipment that comes with 7G-DCT.

<sup>1</sup> Integral component of Mercedes-Benz Intelligent Drive. More on page 32.

## Chassis & suspension.

The A-Class's driving characteristics can be tuned to individual requirements alongside the standard-specification configuration of the chassis and steering with the optionally available combination of the sports suspension and Direct-Steer system.

**Chassis and steering.** The chassis facilitates maximum driving stability and optimum ride comfort – thanks to intelligent weight distribution, its McPherson front axle and four-link rear axle. The rack-and-pinion steering with the STEER CONTROL assistance system enables precise handling in critical driving situations.

**Sports suspension** (part of the optional AMG Line design and equipment line and the optional Dynamic Handling package). The sports suspension blends agility and handling safety with good road roar and tyre vibration characteristics. The springs and dampers have sportily taut tuning, whilst the level of the car is lowered by 15 mm – rolling movements are reduced and driving stability is increased.

**Direct-Steer system** (part of the optional AMG Line design and equipment line and the optional Dynamic Handling package). The Direct-Steer system ensures that the steering movements can implement an even more immediate response. It significantly reduces the steering effort required,

in tight bends, for instance, or when parking. The straight-line stability is especially high at fast speeds and the feedback which the driver receives on the driving situation is very precise.

**4MATIC.** In its latest version the permanent all-wheel drive system 4MATIC offers fully variable torque distribution between the front and rear axle. This facilitates sporty driving characteristics with optimum traction in different driving conditions.



Agility coupled with high comfort.

## Integral safety concept.

The vision of accident-free driving impels us. With our integral safety concept we are coming closer to achieving this goal – this is a holistic approach which can increase safety in every situation.

As the inventor of the motor car we feel a special responsibility for road safety. That's why we became the first car manufacturer to develop an integral safety concept that seamlessly combines active and passive safety measures to provide comprehensive protection. The holistic approach is divided up into four phases and offers safety solutions for every situation. These include systems for safe driving, which help prevent hazards by providing timely alerts and assistance. Our unique PRE-SAFE® system<sup>1</sup> is triggered in response to danger and activates anticipatory measures to protect the occupants. If a collision should occur despite these precautionary measures, other technologies provide the required protection. We have also considered the time immediately after an accident by developing solutions that can prevent serious injury and enable the emergency services to provide rapid assistance. A selection of these technologies for the “Safe driving”, “In the event of danger”, “In an accident” and “After an accident” phases is presented on the pages which follow.

**Safe driving: ATTENTION ASSIST<sup>1</sup>** (standard). This drowsiness-detection system is especially useful on long trips. At speeds of between 80 and 180 km/h, ATTENTION ASSIST warns the driver as soon as it detects signs of drowsiness. Sensors analyse driving behaviour and can detect deviations from a previously determined, individual driver profile.



If ATTENTION ASSIST detects signs of driver drowsiness, it recommends taking a break.

**Safe driving: COLLISION PREVENTION ASSIST<sup>1</sup>** (standard). At speeds of more than 7 km/h the system is able to detect when distances between the vehicle in which it is fitted and those in front or stationary obstacles are too short. If a hazard is detected the driver is given both visual and acoustic warnings. If the driver applies the brakes at the same time, Adaptive Brake Assist can place at the driver's disposal the precise amount of braking power calculated to offer the optimum scope for preventing an impending collision under ideal circumstances.



The COLLISION PREVENTION ASSIST can recognise a safety margin that is too short and warn the driver.

<sup>1</sup> Integral component of Mercedes-Benz Intelligent Drive. More on page 32.



**Safe driving: ADAPTIVE BRAKE** (standard). A driving dynamics control system with a modular structure. It offers additional safety and comfort functions alongside a base function such as the anti-lock braking system (ABS)<sup>1</sup>. The “dry braking” function can remove the film of water from the brake discs in wet conditions – the brake’s response time and therefore the stopping distance can be reduced. “Priming” ensures that the brake pads are placed against the brake discs as soon as the driver takes their foot off the accelerator pedal quickly. The time gained shortens the response time of the brakes. When moving off on an incline unintended rolling back is prevented during the space of time when the foot is moving from the brake pedal to the accelerator. If you briefly depress the brake pedal more firmly whilst the vehicle is stationary, the standard-specification HOLD function keeps the vehicle at a standstill, even if the driver takes their foot away from the brake pedal.

**Safe driving: DISTRONIC PLUS<sup>1</sup> proximity control** (option). The proximity control uses short-range and long-range sensors to maintain the desired safe distance to the vehicle in front. The system operates between 0 and 200 km/h and is also helpful in city traffic or stop-and-go traffic as the sensor can operate in a range of between 0.2 and 200 metres. The system can automatically slow down the vehicle and also accelerate it again.

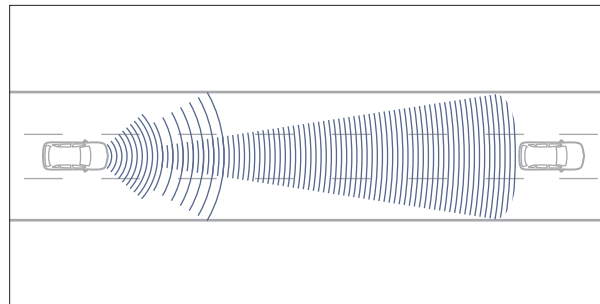

The DISTRONIC PLUS proximity control supports drivers in automatically keeping their vehicle at a safe distance from the vehicle in front.

The DISTRONIC PLUS proximity control is only available in conjunction with the optional 7-speed dual clutch transmission 7G-DCT.

**Safe driving: Lane Keeping Assist/Blind Spot Assist<sup>1</sup>** (option, both part of the optional Lane Tracking package<sup>1</sup>). With the aid of the white lane markings, Lane Keeping Assist is able to detect a line and through gentle steering-wheel vibrations warn the driver if they are in danger of leaving the lane unintentionally. Blind Spot Assist uses two radar sensors to monitor the area which can only be seen poorly by the driver directly alongside and behind the vehicle. If the assistance system detects the danger of an impending collision with another vehicle when changing lanes, the driver is warned by both visual and acoustic signals if the car is travelling at 30 km/h or more.

**Safe driving: Intelligent Light System<sup>1</sup>** (option). The system has six functions: country mode, motorway mode, enhanced fog lamp function, cornering light function, active light function plus the Adaptive Highbeam Assist<sup>1</sup>. The latter always provides the best possible low-beam headlamp range. The headlamps are dimmed automatically as soon as an oncoming vehicle with its lights on is detected. The LED daytime running lamps integrated into the headlamps plus the LED tail lights enhance perceptual safety during the daytime.

**In the event of danger: PRE-SAFE<sup>®</sup> system<sup>1</sup>** (option). The preventive occupant protection system PRE-SAFE<sup>®</sup> is able to recognise critical driving situations in advance and, if necessary, it can activate safety systems which help to reduce the risk of injury to occupants in case they should be needed. This is based on PRE-SAFE<sup>®</sup> continuously monitoring sensor data from systems like the ESP<sup>®1</sup> and BAS<sup>1</sup>, and can thus, for example, recognise driving situations

such as oversteer/understeer as well as emergency braking. If a critical driving situation is detected, in fractions of seconds the belts on the front seats can be reversibly tensioned and the side windows and optional sliding sunroof automatically closed, so that the belts and airbags deploy their full protective effect should an impact occur.

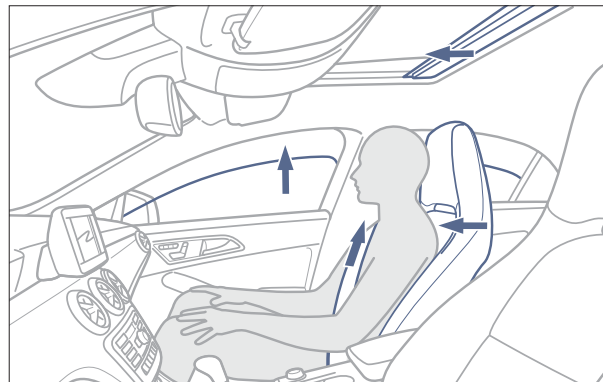

PRE-SAFE<sup>®</sup> can recognise critical driving situations and initiate preventive measures to protect the occupants.

**In an accident: active bonnet** (standard). It can reduce the risk of injury to pedestrians or cyclists if they are involved in a collision with the bonnet in a speed range between 25 and 55 km/h. To cushion the blow, the bonnet is raised 6 centimetres at the rear by means of pyrotechnics.

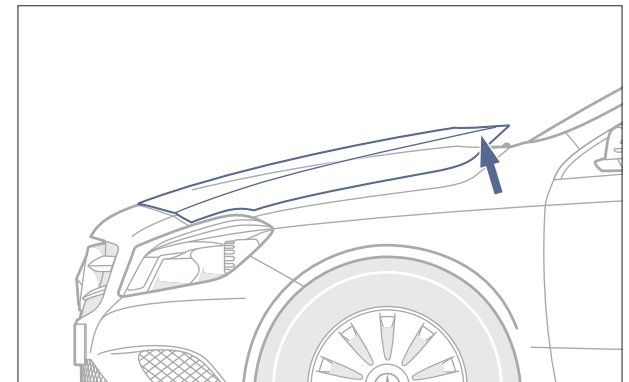

The active bonnet helps to reduce the risk of injury to pedestrians and cyclists in collisions.

<sup>1</sup> Integral component of Mercedes-Benz Intelligent Drive. More on page 32.

**In the event of an accident: restraint systems** (standard). Mercedes-Benz ensures that the 3-point seat belts, tensioners, belt force limiters and airbags are all coordinated optimally to minimise any injuries. In addition to the high-strength bodyshell structure and the highly stable occupant cell, seven standard-fit airbags contribute towards optimum

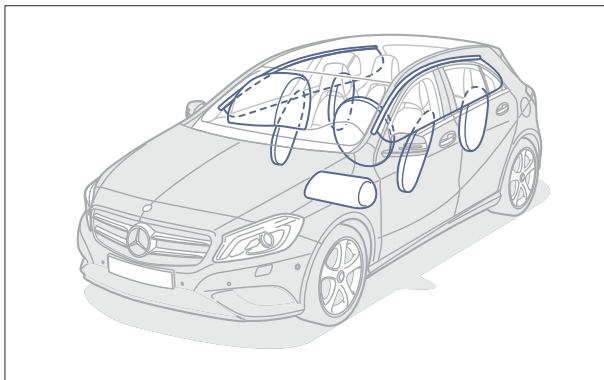

Standard equipment includes windowbags over both rows of seats, airbags and sidebags for the front-seat occupants as well as a driver kneebag.

protection of the vehicle occupants: front airbags, which can be deployed in two stages, depending on the impact severity and accident characteristics, windowbags between the A- and C-pillars and sidebags for the driver and front passenger. The kneebag can further reduce the forces exerted on the driver during an accident. Sidebags are available on the left and right in the rear as an optional extra. If the crash sensors detect an accident, the seat belts are tensioned in a few milliseconds to secure the occupants in their seats. The belt force limiters, in turn, reduce the tension where appropriate in order to lessen the load on the thorax.

**After an accident: Mercedes-Benz emergency call system** (component of COMAND Online). This system can make an emergency call automatically using a mobile phone which is on standby and connected to the vehicle as soon as the restraint system detects an accident. At the same time, the GPS position data and other data about the vehicle are transmitted to the Mercedes-Benz emergency call centre,

after which a voice connection is established. The emergency control system can also be triggered manually.

**Measures after an accident.** In order to reduce consequential damage and, where necessary, to support the rescue of the occupants, Mercedes-Benz has developed further measures. These include the automatic engine cut-off or the activation of the hazard warning lamps and interior emergency illumination. The central locking also opens automatically and thus makes it easier to open the doors after an accident. In addition Mercedes-Benz makes Guidelines for Rescue Services available; helpers can download them in different languages all over the world from the internet at [www.mercedes-benz.de/rettungsleitfaden](http://www.mercedes-benz.de/rettungsleitfaden). As you can see, at Mercedes-Benz consideration has been given to safety in every situation.

## Multimedia systems.

The A-Class offers a full range of entertainment systems, from the Audio 5 USB and the optional Audio 20 CD system with Becker® MAP PILOT to the optional COMAND Online multimedia system.



COMAND Online facilitates user-friendly operation of the main information and communication functions via a single display with TFT technology with a diagonal of 17.8 cm.

**COMAND Online** (option). Amongst the features offered in the latest version are a larger memory for navigation functions and topographical map display. The multimedia system boasts a 17.8 cm high-resolution display with TFT technology and can now also show BMP and PNG image formats. Further functions include: Music Register with a 10 GB hard disc, Cover Flow function, a DVD drive for video and audio DVDs, CDs and MP3 files. Via an internet-capable mobile phone the online browser enables access to the internet and to various mobile services from Mercedes-Benz. Via a USB connector, a slot for SD memory cards and a Bluetooth® interface external data carriers and mobile phones can be connected. The system is controlled via an intuitively operated Controller and the buttons in the multifunction steering wheel. The LINGUATRONIC enables the COMAND Online to be operated via voice entry.

**Drive kit for the iPhone®** (option). With the drive kit, including a cradle, an iPhone® 4/4S can be connected to the Audio 5 USB radio. The MB Drive App optimally coordinates the function and design of the iPhone® with the A-Class and impresses with features that are important during a journey: telephoning via the hands-free system, operating the music collection and internet radio plus clever navigation. There is also a Car Finder which takes you back to the parked car time and again. In conjunction with Audio 20 CD and



With the drive kit for the iPhone® and the MB Drive App you can already integrate your smartphone's functions with the Audio 5 USB.

COMAND Online the matching drive kit plus for the iPhone® 4/4S can be selected.

**Audio 20 CD** (option). The multimedia system boasts a TFT display with a 14.7 cm screen diagonal. Thanks to its integral CD drive both MP3 and WMA/AAC files can be played. As an option a 6-disc CD changer can be added to its specification. Audio 20 CD can be conveniently operated via the multifunction steering wheel and the Controller in the



The functions provided by the Becker® MAP PILOT are indicated on the Audio 20 CD display and the multifunction display in the instrument cluster.

centre console, and it includes an integral telephone keypad, a Bluetooth® interface with a hands-free function and a USB socket in the stowage compartment on the centre console. Six loudspeakers bring you pristine listening experiences.

**Becker® MAP PILOT** (option). Fully integral, the Becker® MAP PILOT with 3D map navigation can be operated using voice entry via the Controller or the multifunction steering wheel. It can be individualised in next to no time by downloading current map data and additional functions.

**Harman Kardon® Logic 7® surround sound system** (option). With twelve loudspeakers, including a woofer, and a 9-channel DSP amplifier, in conjunction with COMAND Online the 450-watt Dolby Digital 5.1 system ensures an exquisite listening experience. The surround sound playback can be individually tuned to the entire passenger compartment, the front compartment, the centre area or the rear compartment.

## Assistance systems.

Alongside numerous safety systems, various comfort assistance systems are available for the A-Class, too. They can provide timely warnings of potentially critical situations and so help the driver to avoid dangers.

**Reversing camera**<sup>1</sup> (option, in conjunction with Audio 20 CD or COMAND Online). The reversing camera with a wide-angle lens and guide lines switches on when reverse gear is engaged and provides additional support for the driver by showing on the screen what is in the area directly behind the vehicle.

**Active Parking Assist**<sup>1</sup>, including **PARKTRONIC**<sup>1</sup> (option). With the Active Parking Assist the vehicle looks for a suitable parking space by itself at a speed of up to 35 km/h. As soon as the driver confirms a suggestion for a parking space and engages reverse gear, the Active Parking Assist

automatically parks the car at the press of a button. The driver then only needs to actuate the gearshift, the accelerator and brake pedal. The Active Parking Assist deals with the steering on its own. The system works extremely precisely: for the automatic parking procedure the parking space has to be just 1.00 metre longer than the vehicle.

**Speed Limit Assist** (included with the optional COMAND Online system). Speed Limit Assist can detect speed-limit signs and display them as symbols on the instrument cluster and in COMAND Online on the navigation screen. They remain displayed there until the speed restriction is lifted

or changed. To this end, a windscreen-mounted camera monitors the area in front of the car on a permanent basis. The camera can filter out round traffic signs, be they speed-limit signs at the side of the road or on a gantry above the road. To detect the signs, the system also draws on the data stored in the navigation system's digital map, thus also enabling it to take account of the vehicle entering or leaving urban areas. Speed Limit Assist is especially helpful on routes with variable speed limits or road works.



During parking, the COMAND Online central display shows the area behind the car.



The display in the instrument cluster gives you a clear picture of what is happening during the current parking process.



The information from Speed Limit Assist is shown both in the instrument cluster and in the COMAND Online central display.

<sup>1</sup> Integral component of Mercedes-Benz Intelligent Drive. More on page 32.

## Light and climate control.

The optionally available Light and Sight package underlines the safety standards in the A-Class and stylishly showcases the interior in darkness. The luxury automatic climate control THERMOTRONIC contributes towards a pleasant interior climate.

**Light and Sight package** (option). The Light and Sight package enhances safety and improves the driver's perception of the traffic – an invaluable benefit in particular during darkness or in poor weather conditions. The package comprises safety-relevant features such as windscreen wipers fitted with a rain sensor and an enlarged washer fluid reservoir, exit and warning lamps for the driver's and front-passenger door, plus a warning and ambient lamp for the tailgate. Quite apart from the safety aspects, the package also increases the high-class appeal of the interior. The integral ambient lighting in the trim on the dashboard and the door shells and door pulls also lends the interior design of the A-Class



The optionally available Light and Sight package highlights the interior design to practical and stylish effect in equal measure.

a stylish and exclusive touch. In conjunction with sports seats the opening between the head restraint and the seat backrest is stylishly illuminated. This pleasant overall impression is enhanced by sun visors with an illuminated interior mirror, footwell lighting for the driver and front passenger and in the rear, illuminated door sill panels at the front, separately controllable reading lamps on both the left- and right-hand side in the rear – and by a downlighter for the rear compartment.



The optional luxury automatic climate control THERMOTRONIC ensures pleasant interior temperatures.

**THERMOTRONIC** (option). The luxury automatic climate control THERMOTRONIC has separate temperature controls for each side of the interior, allowing the driver and front passenger to travel in comfort at the individual temperature of their choice. At the touch of a button the 2-zone system works fully automatically with an integral particulate matter activated charcoal filter against dust, pollen and odours. At the back of the centre console there are also two air outlets for the rear compartment. THERMOTRONIC keeps the desired temperature constant and also takes exterior factors such as sunlight, air quality and humidity into account via its sensors. This means that there is always a pleasant atmosphere in the A-Class.

## Seats.

The seats are offered in three different variants, meeting individual demands regarding ergonomics, seating comfort and safety.

The standard-specification seats have high backrests, offer good lateral support and feature black fabric upholstery.

The optionally available saloon seats with three cross-piping elements in the extended shoulder area can be ordered either in fabric or ARTICO man-made leather in the colours black or crystal grey. The optional high-quality sports seats with integral head restraints are part of all the design and equipment lines plus the Exclusive packages. They ensure high levels of seating comfort. Several upholsteries are available to choose from, including seat covers in ARTICO



The comfortable front seats in the A-Class impress with their ergonomics and wide-ranging adjustment options.

man-made leather/fabric plus entirely in ARTICO man-made leather/DINAMICA microfibre or fine leather. Depending on the equipment, drivers can select from the colours black, crystal grey and nut brown.

**Seat Comfort package** (option). The seats in the Seat Comfort package are characterised by their specific seat cushion design featuring an accentuated shoulder area. They offer the driver and front passenger special comfort on long journeys. The package comprises height adjustment plus seat cushion inclination adjustment for both front seats.



The A-Class offers high levels of seating comfort for the rear passengers, too.

Numerous possibilities for ergonomic individualisation and adjustment to the preferred seat position equal yet more seating comfort.

**4-way lumbar support for the driver and front passenger** (option). The backrest curvature can be individually adjusted to meet the needs of the driver and front passenger. Two air cushions are integrated in the backrests of both front seats. Via two control valves they can be inflated or deflated as required, facilitating individually tailored support for the lumbar spine. The height of the air cushions is also adjustable.

**Electric seat adjustment with memory function** (option). On request the driver's and front passenger seat are electrically adjustable. The memory function can save three individual settings for the position of the seats, the head restraint (not in the case of the sports seats) and the exterior mirrors, and they can be called up again at any time.



## Roof and space.

The A-Class is impressively spacious for a vehicle in the compact class. The panoramic sliding sunroof lets lots of light in and ensures an even more generous sense of spaciousness. The load compartment offers plenty of room for luggage.

**Panoramic sliding sunroof** (option). The panoramic sliding sunroof consists of an electrically operated glass sliding roof running on the exterior. The large glass surface offers a generous transparent area and lets lots of light into the interior, giving rise to a particularly light and friendly ambience. A roller blind can be operated electromotively and provides protection against annoying solar radiation. The wind deflectors with a net structure ensure that the noise level stays as low as possible when travelling with the roof open. In conjunction with the optional Light and Sight package the roof closes automatically if it rains.



Thanks to the panoramic sliding sunroof the A-Class appears even lighter and more spacious through the incidental light.

**Load compartment.** If required the rear seat backrests can be folded in a ratio of 1/3 : 2/3, giving a stowage compartment of up to 1157 litres with a 1.24-metre-long virtually flat load compartment area. When using the A-Class as a 5-seater the load compartment capacity is 341 litres.



The interior can be transformed into a generous load area in just a few simple steps.

**Stowage Space package** (option). The Stowage Space package provides a variety of organisational aids for placing and stowing various items. The specification of the package includes a spectacles compartment in the overhead control panel, a stowage box under the front seats, luggage nets on the driver's and front passenger seat backrests, in the front-passenger footwell and on the side of the boot as well as beneath the parcel shelf and a practical 12 V socket in the boot.



The practical Stowage Space package ensures that the A-Class offers plenty of room for storing various items.

## Sports model A 250 Sport – engineered by AMG.

The sports model, the A 250 Sport, impresses with its expressive design and promises added dynamism thanks to an AMG sports suspension that has been developed in-house and features a specific front axle.



An exceptional character and powerful dynamics, combined in the A 250 Sport.

For special driving dynamics the A-Class is available as the sports model A 250 Sport. It boasts an AMG sports suspension – featuring a specific front axle and sporty engine and transmission tuning – developed by the specialists at Mercedes-AMG. The further equipment is based on the AMG Line design and equipment line, supplemented by other exterior and interior features. These include the striking diamond radiator grille and the characteristic red trim on the AMG front and rear apron plus the red highlight rings in the headlamps. The athletic look is added to by the 5-spoke AMG light-alloy wheels which are painted black with a high-shine finish and shod with 235/40 R 18 tyres. The perforated brake discs at the front, the red brake callipers at the front and rear plus the sporty engine sound ensure that the A 250 Sport exudes dynamism. The two-pipe exhaust system with oval tailpipe trim in polished stainless steel and the “Sport” badges on the front wings complete the look.

The A 250 Sport delights with characteristic features in the interior, too. This is due in the main to the sports seats with upholstery in ARTICO man-made leather/DINAMICA microfibre and with red contrasting topstitching plus the matching red 3-point seat belts. The hallmark A 250 Sport highlights are also to be found in the red rings on the air outlets and in the red needles on the sporty instrument cluster. The 3-spoke multifunction steering wheel is in nappa leather and also has red contrasting topstitching, as do the armrests in the centre console and the doors. The door centre panels are in black DINAMICA microfibre, and the trim sports a carbon fibre look. The dynamic impression is accentuated by the sports pedals in brushed stainless steel with rubber studs and door sill panels at the front in aluminium. In addition to all this, cord floor mats with black piping, red contrasting topstitching and “Sport” lettering are also part of the sports model’s host of equipment.



The sports seats in ARTICO man-made leather/DINAMICA microfibre upholstery with red contrasting topstitching.

## A 45 AMG 4MATIC exterior.

Visibly more powerful: the exterior of the A 45 AMG 4MATIC clearly shows that its roots lie in Affalterbach. Examples of these cues are the AMG light-alloy wheels plus the AMG sports exhaust system, and above all the front and rear aprons featuring an AMG design. → [www.mercedes-amg.com](http://www.mercedes-amg.com)

Sportiness as far as the eye can see: the AMG front apron with black flics and the AMG radiator grille with a twin louvre move impressively into the field of vision. Elements painted titanium grey matt in the front and rear apron plus side sill panels lend the dynamic design of the vehicle

an additional athletic touch. An equally powerful impression is made by the AMG 5-twin-spoke light-alloy wheels, painted titanium grey and with a high-sheen finish. With its uncompromisingly sporty character it has clearly earned the “TURBO AMG” lettering on the wings. As most people

only ever see it from behind, the A 45 AMG is impressive there, too: the AMG sports exhaust system with its specific AMG tailpipe trim design.



The two-pipe AMG sports exhaust system and AMG-design rear apron.



The Turbo AMG lettering marks it out as a real top athlete.



Optional: AMG wheel bolt cover and red-painted brake callipers.



The AMG-design front apron with black flaps, the AMG radiator grille and the light-alloy wheels painted titanium grey and with a high-shine finish demonstrate the power of the A 45 AMG even at a standstill.

## A 45 AMG 4MATIC interior.

An athlete through and through on the inside, too: the interior of the A 45 AMG 4MATIC is more of a cockpit than a driver's compartment. This is thanks to the sports seats with their red topstitching plus red belts – but also the AMG-specific design of the instrument cluster.



Enter the world of motorsport in fitting style – through the driver's door. AMG door sill panels herald in the sporty nature of the interior. The AMG DRIVE UNIT offers direct access to the transmission modes. Thanks to the AMG instrument cluster with its AMG main menu, including Racetimer and the AMG start-up indicator, you always have a good overview of everything – and with the 3-spoke sports steering wheel with the flattened bottom section and shift paddles you have a good grip on everything, too, whilst the sports seats in ARTICO man-made leather/DINAMICA microfibre with red topstitching provide optimum support, even in sharp bends. Red belts and rings in the ventilation outlets complete the sporty interior.

The AMG instrument cluster and the air nozzles with red surrounds inject sportiness into the cockpit.



Always offer optimum support: the sports seats in ARTICO man-made leather/DINAMICA microfibre with red topstitching and red belts.

## A 45 AMG 4MATIC technical details.

Records are part of sport at AMG too: the AMG 2.0-litre turbocharged engine is the most powerful 4-cylinder engine in the world to be produced in series. And further AMG technology puts this on the road in particularly impressive fashion.

**AMG 2.0-litre 4-cylinder turbocharged engine.** A real power package: with 450 Nm and 265 kW (360 hp) the 2-litre turbocharged unit is the most powerful series-produced 4-cylinder engine in the world. It achieves an output of 181 hp per litre of displacement. This is made possible



The centre of power: the AMG 2.0-litre 4-cylinder turbocharged engine.

through highly precise piezo injectors, a Twinscroll turbocharger, forged pistons and crankshaft and the experience gained from 45 years of AMG motorsport. At the same time its combined consumption in the A 45 AMG is just 6.9 l/100 km – for these output values an incomparable result. Amongst the features supporting it here is the ECO start/stop function. The high-performance unit is built entirely by hand in accordance with the traditional AMG philosophy “one man, one engine” – which is clearly evident on the AMG engine badge with the signature of the AMG technician responsible.

**AMG high-performance braking system.** The fastest one standing wins. This is why the A 45 AMG boasts internally ventilated and perforated brake discs, which release more braking energy. At the front axle in the impressive size 350 x 32 mm with a 4-piston fixed calliper. And at the rear with 330 x 22 mm, where a 1-piston floating calliper brings the vehicle to a standstill faster. All of which adds up to the fact that the vehicle’s sheer power can be kept under control at all times.

**AMG SPEEDSHIFT DCT 7-speed sports transmission.**

The incredible power of the AMG engine is optimally transformed into propulsion by the sports transmission. Rapid gear shifting without interruptions to tractive power, with shift times like those in the SLS AMG GT and three differently tuned transmission modes (C, S and M) are available here. A Racestart function, partial cylinder shut-off when upshifting and the double-declutching function when shifting down create a racing atmosphere and ensure a sound experience like that in motorsport.



**AMG Performance 4MATIC all-wheel drive system.**

450 Nm of torque are delivered precisely where they are needed in the A 45 AMG: on the road. This happens courtesy of a fully variable, performance-oriented all-wheel drive system, which – with its AMG-specific electrohydraulic control – ensures optimum traction and thus transforms the unfettered force into dynamic propulsion.

**AMG speed-sensitive sports steering and AMG sports suspension.** In combination with the AMG sports suspension and the front and rear axles specially developed for the A 45 AMG, the electromechanical AMG speed-sensitive sports steering offers high steering precision plus agile handling – for sporty driving pleasure where you always stay in control.



Autonomous steering knuckles at the front with AMG-specific elastokinematics increase dynamism through stiffer axle bearings.

## AMG Performance Studio.

An incomparable AMG vehicle becomes a one-off specimen in the AMG Performance Studio. This is where you can lend your vehicle more understatement on a totally individual basis, or have it converted to become even more dynamic – right through to racing car status. How you want to drive your A 45 AMG 4MATIC is entirely up to you.



The AMG performance seats in conjunction with the AMG Exclusive package.

In the AMG Performance Studio your A 45 AMG is given even more personality. You can have the vehicle tuned more tautly with a performance suspension, give it an even more dominant appearance with the AMG Exterior Carbon-Fibre package or the AMG Night package, or you can have the vehicle sound even more powerful with the AMG performance exhaust system, including specific tailpipe trim. You can fit a few other eye-catching features in the form of brake callipers painted red and two exclusive light-alloy wheel designs. On request you can increase the top speed to 270 km/h with the Driver's Package. And exclusive upgrades are available for the interior, too: the AMG performance seats, for instance, with increased lateral support, an AMG performance steering wheel including the E-SELECT lever plus the master key with the AMG emblem. The AMG Performance Studio leaves virtually nothing to be desired – right through to a one-off specimen.



The A 45 AMG with the Aerodynamics package and multi-spoke AMG light-alloy wheels is one thing above all else: a power package.

## Standard equipment.

The A-Class offers hallmark Mercedes comfort as standard.



Sportiness coupled with quality: the A-Class impresses on the exterior with unusual ideas and painstaking attention to detail. The ex-factory specification includes steel wheels with 10-hole wheel trim and 195/65 R 15 tyres (205/55 R 16 in conjunction with the A 200 CDI and A 200) plus a compact rear bumper in the vehicle colour with a black grained diffuser insert. The latest-generation assistance systems, such as COLLISION PREVENTION ASSIST<sup>1</sup> and ATTENTION ASSIST<sup>1</sup>, are already included as part of the standard specification.



<sup>1</sup> Integral component of Mercedes-Benz Intelligent Drive. More on page 32.





001



021

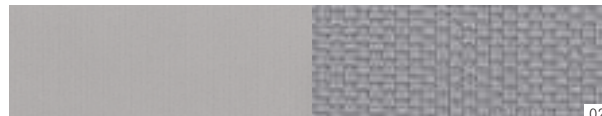

028



101



108



The A-Class impresses with its high functionality. Its standard-fit equipment includes the air conditioning and the Audio 5 USB radio with a twin tuner, three-line display and USB interface. The interior scores points with a 3-spoke multifunction steering wheel with 12 function buttons, the multifunction display in the instrument cluster and a hinge-type stowage compartment in the armrest for the driver and front passenger. The standard trim features a honeycomb-look. The seats and door centre panels are covered in black fabric. On request saloon seats with other upholsteries and colours can be selected.

---

**Standard seat model**

---

001 black (fabric)

---

**Saloon seat model (option)**

---

021 black (fabric)

028 crystal grey (fabric)

101 black (ARTICO man-made leather)

108 crystal grey (ARTICO man-made leather)

---

**Trim**

---

Honeycomb-look

---

The illustrations show the optionally available drive kit for the iPhone®.

## Style.

The Style design and equipment line lends the A-Class a confident air.

The specification of the Style design and equipment line includes 10-spoke light-alloy wheels with 205/55 R 16 tyres. A radiator grille with two louvres in the vehicle colour and chrome trim ensures a youthful and autonomous vehicle character.











451



101



455



108



The optional Style design and equipment line adds individual highlights. The interior boasts sports seats in fabric/ARTICO man-made leather with contrasting topstitching, either in the colours black or black/white, an instrument cluster featuring a display with TFT technology, black headlining (grey headlining is optional) plus black matrix-look trim and ventilation outlets with surfaces in silver chrome.

---

**Sports seat model**

---

451 black (ARTICO man-made leather/fabric)

455 black/white (ARTICO man-made leather/fabric)

---

**Saloon seat model**

---

101 black (ARTICO man-made leather)

108 crystal grey (ARTICO man-made leather)

---

**Trim**

---

black matrix-look

---

## Urban.

The A-Class becomes even sportier with the Urban design and equipment line.

Available on request, the Urban design and equipment line showcases the A-Class in a sporty, expressive way and impresses with its 5-twin-spoke light-alloy wheels with 225/45 R 17 tyres, a radiator grille featuring a silver-coloured twin louvre with chrome trim and a two-pipe exhaust system with chrome-look tailpipe trim.









The interior of the Urban design and equipment line displays enhanced sportiness with its sporty instrument cluster featuring a display with TFT technology, and sports seats in black or crystal grey, checked-pattern trim, a 3-spoke multifunction steering wheel with perforated leather and contrasting topstitching plus door centre panels and armrests which feature contrasting topstitching all over. In addition to all this, saloon seats with ARTICO man-made leather upholstery can also be selected in black or crystal grey.



361



101



368



108



---

#### Sports seat model

361 black (ARTICO man-made leather/fabric)

368 crystal grey (ARTICO man-made leather/fabric)

---

#### Saloon seat model

101 black (ARTICO man-made leather)

108 crystal grey (ARTICO man-made leather)

---

#### Trim

black checked pattern

crystal grey checked pattern

---

## AMG Line.

The optional AMG Line design and equipment line gives the A-Class a powerful appearance.

Dynamism even at a standstill – visible signs of this are the AMG bodystyling, consisting of a front and rear apron plus side skirts, the silver-coloured radiator grille with two louvres and chrome inserts plus the two-pipe exhaust system with oval tailpipe trim in polished stainless steel. Better handling and more fun at the wheel come courtesy of a lowered sports suspension with the Direct-Steer system. The equipment is rounded off by AMG multi-spoke light-alloy wheels, painted titanium grey, with a high-sheen finish and shod with 225/40 R 18 tyres, plus perforated brake discs at the front and also front brake callipers with Mercedes-Benz lettering.











Characteristic features of the AMG Line design and equipment line's interior are seats in ARTICO man-made leather / DINAMICA microfibre with red contrasting topstitching, door centre panels in black DINAMICA microfibre and black headlining. There is a 3-spoke multifunction sports steering wheel – with a flattened bottom section – featuring nappa leather with red contrasting topstitching and perforation in the area of grip, a sports instrument cluster with red needles and a display with TFT technology, carbon fibre look trim and AMG floor mats in cord with black piping and red contrasting topstitching. The hallmark red contrasting topstitching is on the shift lever in nappa leather and the armrests in the centre console and the doors. The crowning glory? The sports pedals in brushed aluminium with rubber studs and the door sill panels in aluminium at the front.

The illustration on the right shows the extended AMG Exclusive package, which is based on the AMG Line design and equipment line.



---

#### Sports seat model

---

651 black (ARTICO man-made leather / DINAMICA microfibre)

---

#### Trim

---

carbon fibre look

---



## Night package.

Extravagant design ideas and special standards come together in the optionally available Night package. It comprises a high-gloss black radiator grille featuring a 2-louvre look with chrome trim, black exterior mirrors, a waistline trim strip in high-gloss black, 5-twin-spoke light-alloy wheels painted black with a high-sheen finish and 225/40 R 18 tyres plus heat-insulating dark-tinted glass at the rear and rear side windows. The Night package is designed as a purely exterior package for further individualisation, and is based on one of the three design and equipment lines Style, Urban or AMG Line. In conjunction with the AMG Line design and equipment line the Night package comprises 5-twin-spoke AMG light-alloy wheels painted black, with a high-sheen finish and 225/40 R 18 tyres.



## Exclusive package and AMG Exclusive package.



The optional Exclusive package meets the requirements of those looking for a particularly high-quality interior at luxury-segment level. It beguiles with its hallmark Mercedes luxury such as heated sports seats with a 4-way lumbar support for the driver and front passenger, plus black, crystal grey or nut brown leather upholstery. The steering wheel and selector lever are also trimmed with leather, the door centre panels, the armrest and the dashboard are colour-coordinated with them and adorned with ARTICO man-made leather. Floor mats in cord and door sill panels in aluminium at the front round off the appointments.

Based on the AMG Line design and equipment line, an extended AMG Exclusive package featuring two-tone upholstery in black RED CUT leather with red contrasting topstitching is available (please see the illustration on page 73.)



801



808



804

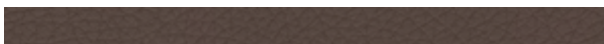
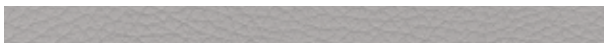

811



---

**Exclusive package**

---

**Sports seat model**

---

801 black (leather)

808 crystal grey (leather)

804 nut brown (leather)

**Trim**

---

black (leather look)

crystal grey (leather look)

nut brown (leather look)

---

**AMG Exclusive package**

---

**Sports seat model**

---

811 black RED CUT (leather)

**Trim**

---

carbon fibre look

## Standard equipment | Selection.



3-spoke multifunction steering wheel with 12 function buttons.



Audio 5 USB.



Air conditioning.



Armrest with stowage compartment.



Power windows, 4.



Automatic headlamp activation.



## Optional extras | Selection.



Bi-xenon headlamp.



Panoramic sliding sunroof.



Trailer coupling.



Illuminated door sill panels in the Light and Sight package.



Audio 20 CD with Becker® MAP PILOT.



THERMOTRONIC luxury automatic climate control.

## Wheels.



Steel wheels with 10-hole wheel trim with 195/65 R 15 tyres (standard for A 180 and A 180 CDI, Code R00).



Steel wheels with 10-hole wheel trim with 205/55 R 16 tyres (standard for A 200 CDI and A 200, Code 643).



10-spoke light-alloy wheels with 205/55 R 16 tyres (standard in conjunction with Style, Code 55R).



5-twin-spoke light-alloy wheels, painted matt black with a high-shine finish, with 205/55 R 16 tyres (option, Code R78).



10-spoke light-alloy wheels with 225/45 R 17 tyres (standard for A 220 CDI, A 250 and A 250 4MATIC, Code R43).



5-twin-spoke light-alloy wheels with 225/45 R 17 tyres (standard in conjunction with Urban, Code R11).



5-twin-spoke light-alloy wheels, painted tremolite grey, with 225/45 R 17 tyres (option, Code 44R).



10-spoke light-alloy wheels with 205/50 R 17 tyres (optional winter wheel, Code 25R).



5-twin-spoke light-alloy wheels, painted himalayas grey, with a high-sheen finish and 225/45 R 17 tyres (option, Code R48).



5-twin-spoke AMG light-alloy wheels, painted titanium grey, with a high-sheen finish and 225/40 R 18 tyres (option, Code 794).



AMG multi-spoke light-alloy wheels, painted black, high-sheen rim flange, with 225/40 R 18 tyres, (option, Code 646).



5-spoke AMG light-alloy wheels, painted black, with a high-sheen finish and 235/40 R 18 tyres (standard for A 250 Sport, Code 774).



5-twin-spoke light-alloy wheels, painted black with a high-sheen finish, with 225/40 R 18 tyres (standard for Night package with Style or Urban, option, Code R38).



5-twin-spoke light-alloy wheels, painted matt black with a high-sheen finish, with 225/40 R 18 tyres (option, Code R10).



Multi-spoke AMG light-alloy wheels, painted titanium grey, with a high-sheen finish and 225/40 R 18 tyres (standard in conjunction with AMG Line, Code 791).



5-twin-spoke AMG light-alloy wheels, painted black, with a high-sheen finish and 225/40 R 18 tyres (standard for Night package in conjunction with AMG Line, option, Code 781).

## Genuine accessories.

Practical, versatile, progressive – there's not much the A-Class can't do. And there are always the genuine accessories from Mercedes-Benz.



With the drive kit plus for the iPhone® and the Digital DriveStyle App the smartphone is extensively integrated in the A-Class.

With the genuine accessories range you can either make your A-Class more practical, more comfortable, or more multimedial. Or all of the above.

With the drive kit plus for the iPhone® your iPhone® 4/4S is extensively integrated into the A-Class. The matching Digital DriveStyle App is available free of charge in the iTunes® App Store. This means that with the Audio 20 CD and COMAND Online you have access to the fundamental contents of your iPhone®, which are shown in the vehicle display and can be easily and safely operated via the Controller on the centre armrest.

With the integration of the iPhone® into the vehicle and the revolutionary user interface design you can seamlessly continue your digital lifestyle in the vehicle. This means that, amongst other things, you have access to the progressive navigation solution from Garmin® with internet-based realtime traffic information, an online POI search and 3D map display. With the voice recognition software audio-based communication with your iPhone® is possible, plus instructions which otherwise require manual input are carried out.

A further highlight is the personalised internet radio from AUPEO! Personal Radio, a customised music program. Following access via genre or artist, tracks matching your personal taste are played. A social/interactive experience is also possible with sharing, posting via Facebook®, Twitter® and Glympse™ and the integration of music plus other contents from the social networks including a text-to-speech function. In addition, an intuitive Car Finder automatically stores the location of the vehicle. Thanks to pedestrian navigation this enables the vehicle to be found again easily.

A further practical feature is the 400 roof box. It has the incredible capacity of around 400 litres, can take loads of up to 75 kg and boasts handle strips on both sides for better handling. In order to make optimum use of the stowage space in the roof box there are items such as the suitably dimensioned luggage set, comprising three bags plus a ski bag for a maximum of two pairs of skis.

And we can top this for the more sporty drivers in the form of a dynamic roof spoiler and a rear apron trim with a diffuser-look. This also lends the A-Class a racy touch in visual terms.

See our range of genuine accessories for yourself – just take a look at our brochure or pay a visit to your authorised Mercedes-Benz dealer.



Practical, aerodynamic, elegant: the roof box offers much more than just stowage space.

## Services.

**Mercedes-Benz Financial Services.** Our sophisticated leasing and financing products are tailored to your individual financial needs, giving you the opportunity to drive your dream car while staying financially flexible. Once you have chosen a model, you can enjoy the peace of mind of knowing that both the vehicle itself and our insurance products will keep you particularly well protected. What's more, our range of service products is designed to ensure that your car stays in top shape while offering transparent, manageable conditions. For further details, speak to your Mercedes-Benz dealer, who will be glad to go through the latest financial services and terms and conditions with you.

**Mercedes-Benz mobility.** Your new car comes complete with the promise of feeling safe on the road. But if you should ever need assistance, Mercedes-Benz Service24h is there to help. Just call the freephone service hotline on 00800 1 777 7777<sup>1</sup>. The integrated telematics service, Mercedes-Benz Contact<sup>2</sup>, is even more convenient: a touch of a button is all it takes to contact the Mercedes-Benz customer centre. If you wish, relevant vehicle and position-related data are transmitted at the same time, thereby allowing the centre to react quickly and provide rapid on-site assistance. Also standard with your new car at no extra charge is the Mercedes-Benz Mobilo<sup>3</sup> mobility package. Whether you have lost your key, had a breakdown which cannot be repaired immediately or suffered damage to the vehicle due to an accident or vandalism, Mobilo helps you reach your destination – anywhere in Europe. Whatever is holding you up, you will soon be able to resume your journey.

**Mercedes-Benz Museum.** Discover what has been moving the world for over 125 years, and embark on a fascinating journey through automotive history in the Mercedes-Benz Museum. More than 1500 exhibits covering an area of 16,500 square metres chart the unique heritage and innovative flair of the inventor of the motor car. You will find one automotive legend after another awaiting you: unique pieces such as the oldest Mercedes still in existence from 1902, supercharged cars or the awe-inspiring Gullwings. The museum is a spectacular sight in its own right too, thanks to an architecture that breaks away from traditional concepts and creates an unprecedented sense of space. Welcome to the Mercedes-Benz Museum – a world of innovation. [www.mercedes-benz-classic.com/museum](http://www.mercedes-benz-classic.com/museum)



<sup>1</sup> Alternative: +49 69 95 30 72 77. <sup>2</sup> Requires a factory-fitted radio, connected to an operational mobile phone. The only charge incurred is the cost of the mobile phone call to the landline network. <sup>3</sup> Once the mobility guarantee has expired (four years), Mobilo can be extended to provide cover in the event of breakdown and insurance claims one year at a time for a maximum of 30 years, provided that regular maintenance is carried out by your Mercedes-Benz service partner.

**Test drive.** The unique feeling of driving a Mercedes cannot be put into words – you have to experience it for yourself. Take a test drive and find out first hand how it feels to drive your dream car. Please contact your nearest Mercedes-Benz dealer for details.

#### **Interactive Owner's Manual and Mercedes-Benz Guides.**

The website also offers an interactive tour, enabling you to acquaint yourself with your dream car. You can view key functions in detail, gain an insight into the car's inner workings or look at the benefits of each model. For further details, go to [www.mercedes-benz.de/owners-manual](http://www.mercedes-benz.de/owners-manual). The "Mercedes-Benz Guides" app lets you explore the highlights of the individual models both online and offline. The app is available free of charge from the Apple® iTunes® Store (iOS) as well as the Google Play store (Android).

**Mobile internet.** The whole world of Mercedes-Benz can be explored at any time with your web-capable mobile device – including specially adapted content for both smartphones and tablets. As well as an overview of all the passenger car models, there are insights into the entire brand world along with a wealth of entertainment offers and direct links to our range of services at [www.mercedes-benz.com](http://www.mercedes-benz.com)

**Mercedes-Benz service contracts.** You need never worry about unexpected workshop costs<sup>4</sup> again: depending on the specific contract, a Mercedes-Benz service contract can cover unforeseen repairs, maintenance or wear parts. As a result, your vehicle stays in great condition – thanks to the Mercedes-Benz quality you can expect from our highly qualified workshop specialists and Mercedes-Benz genuine parts. Your Mercedes-Benz dealer will be pleased to tell you more about the available service contracts and terms and conditions.



**Accident repairs.** Should the worst happen and you find yourself in need of repairs, with the Mercedes-Benz accident repair service you will receive the right assistance for your vehicle and ensure that its high-quality safety features are properly maintained. Whether you need paint, body or glass repair work carried out, the highly trained specialists at your Mercedes-Benz service partner will repair your Mercedes-Benz and get you quickly back on the road again. Further information is available from your authorised Mercedes-Benz dealer.



<sup>4</sup> In accordance with the terms and conditions of the Mercedes-Benz service contracts.

## Dimensions.

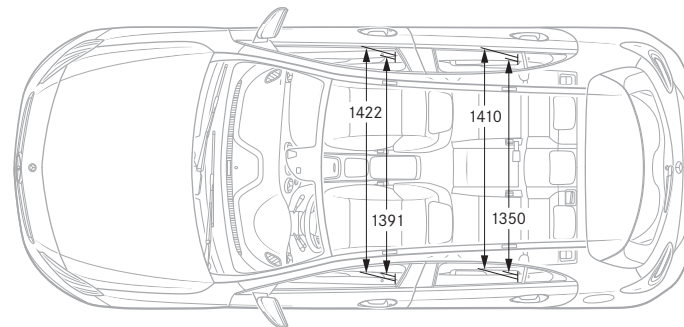
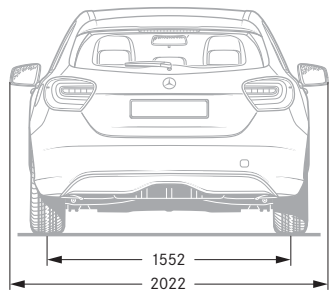
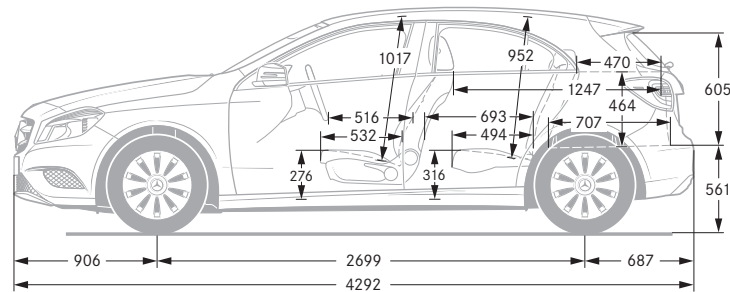
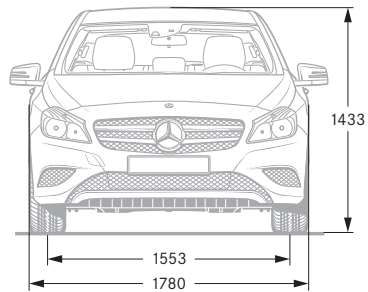

## Paintwork.

### Non-metallic paints (standard)

- 589 jupiter red
- 650 cirrus white
- 696 night black

### Metallic paints (option)

- 162 south seas blue
- 191 cosmos black
- 592 northern lights violet
- 761 polar silver
- 787 mountain grey
- 893 monolith grey
- 894 universe blue

### Special paint (option)

- 662 designo magno mountain grey



## Technical data.

	<b>Diesel engines</b>				
	A 180 CDI	A 180 CDI (7G-DCT)	A 180 CDI BlueEFFICIENCY Edition	A 200 CDI	A 220 CDI
No. of cylinders/arrangement	4/in-line	4/in-line	4/in-line	4/in-line	4/in-line
Total displacement in cc	1461	1796	1461	1796	2143
Rated output <sup>1</sup> in kW (hp) at rpm	80 (109)/4000	80 (109)/3200-4600	80 (109)/4000	100 (136)/3600-4400	125 (170)/3400-4000
Rated torque <sup>1</sup> in Nm at rpm	260/1750-2500	250/1400-2800	260/1750-2500	300/1600-3000	350/1400-3400
Transmissions	6-speed manual	- [7G-DCT]	6-speed manual	6-speed manual [7G-DCT]	- [7G-DCT]
Acceleration from 0-100 km/h in s [7G-DCT]	11.3	- [10.6]	11.3	9.3 [9.2]	- [8.2]
Top speed approx. in km/h	190	190	190	210	220
Tyre size, front	195/65 R 15	195/65 R 15	195/65 R 15	205/55 R 16	225/45 R 17
Tyre size, rear	195/65 R 15	195/65 R 15	195/65 R 15	205/55 R 16	225/45 R 17
Fuel	Diesel	Diesel	Diesel	Diesel	Diesel
Fuel consumption <sup>2</sup> in l/100 km					
Urban [7G-DCT]	4.7-4.5	- [5.0-4.8]	4.2-4.2	5.6-5.3 [5.0-4.8]	- [5.4-5.2]
Extra-urban [7G-DCT]	3.6-3.3	- [4.1-3.8]	3.2-3.2	4.0-3.7 [4.1-3.8]	- [3.8-3.6]
Combined [7G-DCT]	4.0-3.8	- [4.4-4.1]	3.6-3.6	4.6-4.3 [4.4-4.1]	- [4.4-4.2]
CO <sub>2</sub> emissions <sup>2</sup> in g/km combined [7G-DCT]	105-98	- [116-109]	92-92	121-111 [116-109]	- [115-109]
Emission class	Euro 5	Euro 5	Euro 5	Euro 5	Euro 6
Tank capacity in l of which approx. reserve	50/6.0	50/6.0	40/6.0	50/6.0	50/6.0
Boot capacity	341-1157	341-1157	341-1157	341-1157	341-1157
Turning circle diameter in m	11.00	11.00	11.00	11.00	11.00
Kerb weight/payload capacity <sup>3</sup> in kg [7G-DCT]	1395/565	- [1475/525]	1385/465	1445/565 [1475/525]	- [1485/525]
Perm. GVW in kg [7G-DCT]	1960	- [2000]	1850	2010 [2000]	- [2010]

Figures in square brackets apply to engines in conjunction with optional 7-speed dual clutch transmission 7G-DCT.

<sup>1</sup> Figures in accordance with Directive 80/1269/EEC in the currently applicable version. <sup>2</sup> The figures shown were obtained in accordance with the prescribed measuring process (Directive [EC] 715/2007 in the currently applicable version). The figures are not based on an individual vehicle and do not constitute part of the product offer; they are provided solely for the purposes of comparison between different vehicle models.

### Petrol engines

	A 180	A 180 BlueEFFICIENCY Edition	A 200	A 250	A 250 4MATIC	A 250 Sport	A 45 AMG 4MATIC
No. of cylinders/arrangement	4/in-line	4/in-line	4/in-line	4/in-line	4/in-line	4/in-line	4/in-line
Total displacement in cc	1595	1595	1595	1991	1991	1991	1991
Rated output <sup>1</sup> in kW (hp) at rpm	90 (122)/5000	90 (122)/5000	115 (156)/5300	155 (211)/5500	155 (211)/5500	155 (211)/5500	265 (360)/6000
Rated torque <sup>1</sup> in Nm at rpm	200/1250-4000	200/1250-4000	250/1250-4000	350/1200-4000	350/1200-4000	350/1200-4000	450/2250-5000
Transmission	6-speed manual [7G-DCT]	6-speed manual	6-speed manual [7G-DCT]	- [7G-DCT]	- [7G-DCT]	- [7G-DCT]	AMG SPEEDSHIFT DCT 7-speed sports transmission
Acceleration from 0-100 km/h in s [7G-DCT]	9.2 [9.1]	10.3	8.4 [8.3]	- [6.6]	- [6.5]	- [6.6]	- [4.6]
Top speed approx. in km/h	202	190	224	240	240	240	250
Tyre size, front	195/65 R 15	195/65 R 15	205/55 R 16	225/45 R 17	225/45 R 17	235/40 R 18	235/40 R 18
Tyre size, rear	195/65 R 15	195/65 R 15	205/55 R 16	225/45 R 17	225/45 R 17	235/40 R 18	235/40 R 18
Fuel	Premium petrol	Premium petrol	Premium petrol	Premium petrol	Premium petrol	Premium petrol	Super Plus petrol
Fuel consumption <sup>2</sup> in l/100 km							
Urban [7G-DCT]	7.7-7.5 [7.3-7.1]	6.9-6.9	7.7-7.5 [7.3-7.1]	- [8.4-8.3]	- [8.8-8.6]	- [8.4-8.4]	- [9.1-8.8]
Extra-urban [7G-DCT]	4.7-4.3 [4.8-4.5]	4.1-4.1	4.8-4.4 [4.8-4.5]	- [5.0-4.9]	- [5.7-5.6]	- [5.1-5.1]	- [5.9-5.8]
Combined [7G-DCT]	5.8-5.5 [5.7-5.4]	5.2-5.2	5.8-5.5 [5.7-5.4]	- [6.2-6.1]	- [6.8-6.8]	- [6.4-6.4]	- [7.1-6.9]
CO <sub>2</sub> emissions <sup>2</sup> in g/km combined [7G-DCT]	135-128 [133-127]	120-120	136-129 [133-127]	- [145-143]	- [159-156]	- [148-148]	- [165-161]
Emission class	Euro 6	Euro 6	Euro 6	Euro 6	Euro 6	Euro 6	Euro 6
Tank capacity in l of which approx. reserve	50/6.0	40/6.0	50/6.0	50/6.0	56/6.0	50/6.0	56/8.0
Boot capacity	341-1157	341-1157	341-1157	341-1157	341-1157	341-1157	341-1157
Turning circle diameter in m	11.00	11.00	11.00	11.00	11.00	11.00	11.04
Kerb weight/payload capacity <sup>3</sup> in kg [7G-DCT]	1370/565 [1395/525]	1360/565	1370/565 [1395/525]	- [1445/525]	- [1505/525]	- [1465/505]	- [1555/495]
Perm. GVW in kg [7G-DCT]	1935 [1920]	1925	1935 [1920]	- [1970]	- [2030]	- [1970]	- [2050]

<sup>3</sup> Figures according to Directive 92/21/EC, version 95/48/EC (kerb weight with fuel tank 90% full, driver, 68 kg, and luggage, 7 kg) for standard-specification vehicles.

Optional extras and accessories will generally increase this figure and reduce the payload capacity accordingly. Further technical data can be found at [www.mercedes-benz.com](http://www.mercedes-benz.com)

Non-metallic paints

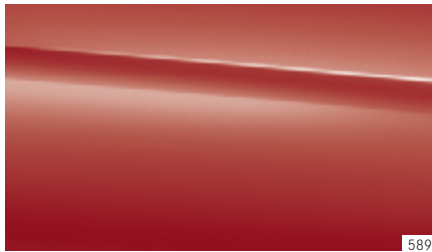

589



650

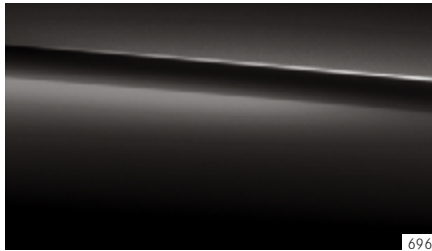

696

Metallic paints

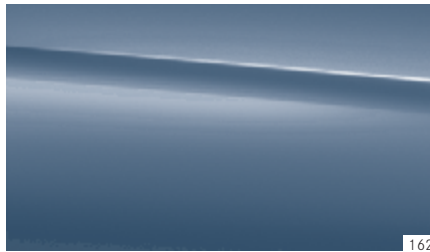

162

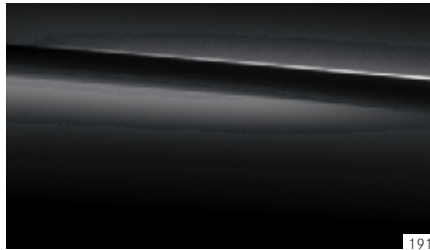

191

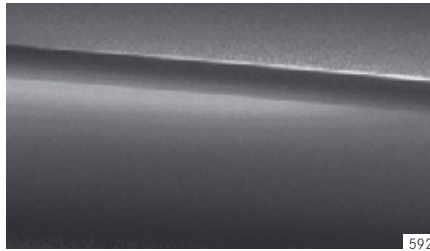

592

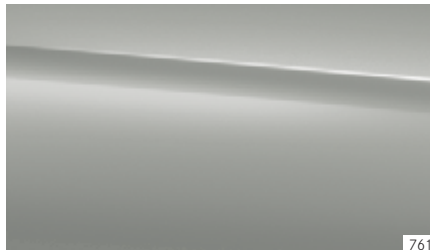

761

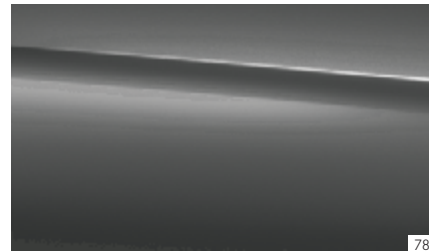

787

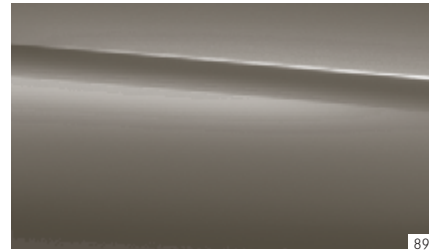

893

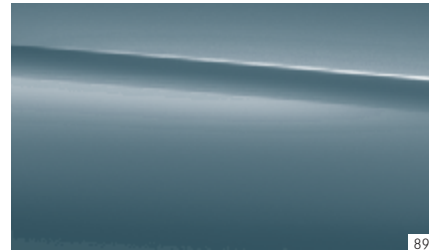

894

Special paint

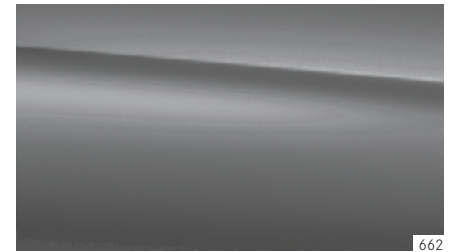

662

**Take-back of end-of-life vehicles.** At the end of its long life, you can return your A-Class to us for environment-friendly disposal in accordance with the EC End-Of-Life Vehicle Directive. But that day lies a long way off.

A network of vehicle take-back depots and dismantlers has been established to make it as easy as possible for you to return your vehicle. You can leave it at any of these points free of charge and, by doing so, make an important contribution to completing the recycling process and conserving resources.

For further information about the recycling and disposal of end-of-life vehicles, and the take-back conditions, please visit the national Mercedes-Benz website.

**Please note:** changes may have been made to the product since this brochure went to press (31.01.2013). The manufacturer reserves the right to make changes to the design, form, colour and specification during the delivery period, provided these changes, while taking into account the interests of the vendor, can be deemed reasonable with respect to the purchaser. Where the vendor or the manufacturer uses symbols or numbers to describe an order or the subject of an order, no rights may be derived solely from these. The illustrations may show accessories and items of optional equipment which are not part of standard specification. Colours may differ slightly from those shown in the brochure, owing to the limitations of the printing process. This brochure is distributed internationally. It provides a general indication of the range of models, features, optional extras and colours available in various countries. Some of the models, features, optional extras and colours shown may not be available in your country or may only be available in a different specification. Additionally some models, features, optional extras and colours may only be available in combination with others. For current and more specific information in relation to the range of models, features, optional extras and colours available in your country, and their pricing, you should contact your nearest authorised Mercedes-Benz Passenger Car Dealer.

[www.mercedes-benz.com](http://www.mercedes-benz.com)